

Visualization And Performance Evaluation Of DT-CWT Based OFDM System In Linear Algebra Perspective

Anju M.Kaimal^{#1}, Anand R^{#2}, Vishnu Prabhu S^{#3}, Premanand V^{#4}

[#]Center for Computational Engineering and Networking, Amrita University
Amritanagar P.O, Coimbatore, India-641112.

Abstract— In this paper, a novel OFDM system has been proposed based on DTCWT. The mathematics behind the proposed OFDM system is explained in linear algebra point of view. Also comparative study has been made between the traditional OFDM and the OFDM based on DTCWT. BER and CCDF of PAPR are used in comparing the performance evaluation of the two systems. Simulated results suggests that the newly proposed system has better BER and PAPR performance when compared to traditional OFDM system. The CCDF suggests that there is 5 dB improvement over the conventional OFDM system.

Keywords— OFDM, Orthonormal basis, FFT, DTCWT, IDTCWT, Wavelet matrix.

I. INTRODUCTION

Most of the modern digital communication system is built with the aid of Orthogonal Frequency Division Multiplexing(OFDM). The technology has gained high popularity since it enables high speed data transmission and also it is more resistive to frequency selection fading. Recent technologies like Digital Audio Broadcasting(DAB), High Definition Television(HDTV), wireless Local Area Network(LAN),etc widely use OFDM.

Any communication system consists of transmitter, channel and receiver. The user signal, which is in digital form, gets modulated with the carrier signal before getting transmitted. In OFDM, the single carrier is divided into several subcarriers. The information is loaded in parallel in each of the subcarrier. OFDM divides the communication channel into equi-spaced frequency bands. A subcarrier is transmitted in each sub band.

In order to prevent mixing of transmitted information, inter carrier interference(ICI) between the subcarriers need to be avoided. Non overlapping rectangular response can prevent ICI. But this scenario demands subcarriers of infinite length in time domain, which is practically impossible. In OFDM, the subcarriers are taken orthogonal, which ensures independence of a subcarrier of each other.

Orthonormal basis set is the primary requirement for modulation and demodulation in OFDM, where each column represent the sub carriers. Some of the popular orthonormal basis are Discrete Cosine Transform(DCT), Discrete Fourier Transform(DFT), Walsh Hadamard Transform,etc. Conventional OFDM systems are based on DFT. DFT can be effectively calculated with the aid of (Fast Fourier Transform)FFT which makes the OFDM system computationally inexpensive and efficient.

The FFT based OFDM suffers from some serious drawbacks. In digital communication, the signal which is

used to modulate the subcarriers have high side lobes in frequency domain. This affect the channel response which can lead to ICI and as well as Inter Symbol Interference(ISI). This drastically increase the Bit Error Rate(BER) of the system.

Another serious demerit of traditional OFDM system is high Peak Average to Power Ratio(PAPR). Due to high PAPR, the non linear amplifier are being forced to operate at lower average power which makes the system ineffective. Also it imposes a challenging constrain in design of power amplifier. Added to this, loss of orthogonality in DFT leads to high ISI.

Owing to all these shortcomings, lot of work has been done to propose alternate choice of orthogonal subcarriers. Wavelet basis has various advantages when compared to Fourier basis, as it provides time frequency view of the data. OFDM implemented with the aid of wavelet basis has several advantages. It has good side lobes suppression and also loss of orthogonality doesn't affect the system greatly. The work focus on use of complex wavelet basis for modulation in OFDM. In complex wavelet system, the basis are complex numbers. Dual Tree Complex Wavelet Transform(DTCWT) is the method used to efficiently implement complex wavelet modulation. Several DTCWT based system is designed and its performance is checked with that of traditional OFDM system.

The paper is organized as follows: Section II tries to provide the theoretical background of OFDM system in linear algebra perspective. Section III is devoted for understanding the mathematics behind the orthonormal basis DFT, Wavelet Transform and DTCWT. Section IV provides insight into various functional blocks in DTCWT based OFDM system. Section V elaborates about two parameter, BER and PAPR, which are widely for performance measurement of OFDM system. Section V focuses on simulation and performance evaluation of OFDM system using various DTCWT basis. Two parameter, BER and PAPR are taken and a study has been made on various factors like design of the subcarrier, number of subcarrier affect the communication system. Simulation results are presented in Section VI and the work is concluded in Section VII.

II. OFDM SYSTEM IN LINEAR ALGEBRA PERSPECTIVE

The section aims to bring the mathematics behind modulation and demodulation in OFDM to limelight.

Let us consider the scenario where the user needs to transmit the message $x = \begin{bmatrix} 1 \\ -1 \end{bmatrix}$. Suppose a matrix

$$A = \begin{bmatrix} \frac{1}{\sqrt{2}} & \frac{1}{\sqrt{2}} \\ \frac{1}{\sqrt{2}} & -\frac{1}{\sqrt{2}} \end{bmatrix} \text{ is provided, where}$$

$$\begin{pmatrix} \frac{1}{\sqrt{2}} \\ \frac{1}{\sqrt{2}} \end{pmatrix}, \begin{pmatrix} -\frac{1}{\sqrt{2}} \\ \frac{1}{\sqrt{2}} \end{pmatrix} \text{ represent the orthonormal basis set. Since}$$

the basis are orthogonal, they are independent and so they can act as subcarriers.

In OFDM modulation at transmitter, the message gets loaded in parallel to its subcarriers as shown below:

$$\begin{bmatrix} \frac{1}{\sqrt{2}} & \frac{1}{\sqrt{2}} \\ \frac{1}{\sqrt{2}} & -\frac{1}{\sqrt{2}} \end{bmatrix} \begin{bmatrix} 1 \\ -1 \end{bmatrix} = (1) \begin{pmatrix} \frac{1}{\sqrt{2}} \\ \frac{1}{\sqrt{2}} \end{pmatrix} + (-1) \begin{pmatrix} \frac{1}{\sqrt{2}} \\ -\frac{1}{\sqrt{2}} \end{pmatrix} = \begin{pmatrix} 0 \\ \sqrt{2} \end{pmatrix} = b \quad (1)$$

The digital data is written as linear combination of the orthonormal basis and are added to get the single vector b. The vector b is transmitted through the channel.

The requirement to perform this modulation in OFDM is the orthonormal basis matrix A. If Fourier basis are taken in columns of A, then (1) is basically IFFT operation. So in conventional OFDM based on DFT, IFFT is used in the transmitter for modulation.

The vector b passes through the channel and reach the receiver. Estimation is done by multiplying the received signal with the demodulation matrix

$$\tilde{A} = \begin{bmatrix} \frac{1}{\sqrt{2}} & \frac{1}{\sqrt{2}} \\ \frac{1}{\sqrt{2}} & -\frac{1}{\sqrt{2}} \end{bmatrix}$$

where $\tilde{A} = A^{-1} = A^H$ (If basis in A is orthonormal)

$$\tilde{x} = \tilde{A}b = \begin{bmatrix} \frac{1}{\sqrt{2}} & \frac{1}{\sqrt{2}} \\ \frac{1}{\sqrt{2}} & -\frac{1}{\sqrt{2}} \end{bmatrix} \begin{bmatrix} 0 \\ \sqrt{2} \end{bmatrix} = \begin{bmatrix} 1 \\ -1 \end{bmatrix}$$

This matrix vector product should be interpreted as projecting the received signal to each of the basis.

$$\begin{pmatrix} \frac{1}{\sqrt{2}} & \frac{1}{\sqrt{2}} \end{pmatrix} \begin{pmatrix} 0 \\ \sqrt{2} \end{pmatrix} = 1$$

$$\begin{pmatrix} \frac{1}{\sqrt{2}} & -\frac{1}{\sqrt{2}} \end{pmatrix} \begin{pmatrix} 0 \\ \sqrt{2} \end{pmatrix} = -1$$

This operation is equivalent to that of FFT if A has DFT basis set are taken in columns. Thus demodulation takes place with the aid of FFT module in receiver.

It can be noted that A satisfies the property

$$A \tilde{A} = \begin{bmatrix} \frac{1}{\sqrt{2}} & \frac{1}{\sqrt{2}} \\ \frac{1}{\sqrt{2}} & -\frac{1}{\sqrt{2}} \end{bmatrix} \begin{bmatrix} \frac{1}{\sqrt{2}} & \frac{1}{\sqrt{2}} \\ \frac{1}{\sqrt{2}} & -\frac{1}{\sqrt{2}} \end{bmatrix} = \begin{bmatrix} 1 & 0 \\ 0 & 1 \end{bmatrix}$$

The beauty of the OFDM system design is that any orthonormal basis can be used to fill the columns of A

provided the condition $A \tilde{A} = I$ is satisfied. So there lies a wide scope to improve the performance of the OFDM system by looking for other type of orthonormal basis such as Discrete wavelet, Complex wavelet, etc, which can be used to replace the traditional OFDM system based on DFT.

III. ORTHONORMAL BASIS SET

Orthonormal basis set is a matrix which contains collection of orthonormal basis vectors. The section presents the mathematics behind the orthonormal basis set of DFT and DTCWT.

A. Fourier Basis

Fourier Basis are widely used for OFDM communication. In fourier series,orthogonal basis can be created by equispaced samples of Complex Exponentials .

The θ is defined as:

$$\theta = 0 \times \frac{2\pi}{N}, 1 \times \frac{2\pi}{N}, \dots, (N-1) \times \frac{2\pi}{N}$$

The N orthogonal basis are created as follows:

$$\text{Base } 0 = e^{j \times 0 \times \theta}$$

$$\text{Base } 1 = e^{j \times 1 \times \theta}$$

$$\text{Base } 2 = e^{j \times 2 \times \theta}$$

⋮

⋮

$$\text{Base } \frac{N}{2} = e^{j \times \frac{N}{2} \times \theta}$$

$$\text{Base } \frac{N}{2} + 1 = e^{j \times \left(\frac{-N}{2} + 1\right) \times \theta}$$

⋮

⋮

$$\text{Base } N - 1 = e^{j \times -1 \times \theta}$$

So DFT is basically finding the projection. So the DFT matrix can be defined as follows:

$$\begin{pmatrix} X(0) \\ X(1) \\ \vdots \\ X(N-1) \end{pmatrix} = \begin{pmatrix} - & - & \overline{Base0} & - & - \\ - & - & \overline{Base1} & - & - \\ & & \vdots & & \\ - & - & \overline{BaseN-1} & - & - \end{pmatrix} \begin{pmatrix} x(0) \\ x(1) \\ \vdots \\ x(N-1) \end{pmatrix}$$

where x represents the sampled signal and X represents the projection values. \overline{Base} represents the complex conjugate of DFT Base. So Inverse Discrete Fourier transform(IDFT) involves representing the signal x as linear combination of DFT basis.

$$\begin{pmatrix} x(0) \\ x(1) \\ \vdots \\ x(N-1) \end{pmatrix} = \begin{pmatrix} | & & & | \\ | & & & | \\ | & Base0 & Base1 & \dots & \dots & BaseN-1 & | \\ | & & & & & & | \\ | & & & & & & | \end{pmatrix} \begin{pmatrix} X(0) \\ X(1) \\ \vdots \\ X(N-1) \end{pmatrix}$$

$$\begin{pmatrix} x(0) \\ x(1) \\ \vdots \\ x(N-1) \end{pmatrix} = X(0) \begin{pmatrix} | \\ | \\ | \\ | \end{pmatrix} + X(1) \begin{pmatrix} | \\ | \\ | \\ | \end{pmatrix} + \dots + X(N-1) \begin{pmatrix} | \\ | \\ | \\ | \end{pmatrix}$$

Fast Fourier Transform(FFT) is used to compute DFT faster and Inverse Fast Fourier transform(IFFT) is used to compute IDFT faster. It can be easily proved that the product of IFFT and FFT matrix will result in unitary matrix.

In OFDM system, IFFT is used in transmitter which performs modulation and FFT is used in receiver for demodulation of received data.

B. Discrete Wavelet Transform

In the recent years, wavelet analysis has gained more attention when compared to Fourier analysis as it has the potential to provide time frequency representation. Owing to this merit, the data rate is adapted to carrier frequency as each symbol datum occupies one period of its assigned subcarrier. Also, a flexible alignment of time-frequency tiling, the effect of noise and interference on the signal can be minimized. The wavelet based system are capable of overcoming known channel disturbances at the transmitter, rather them waiting to deal with them in the receiver.

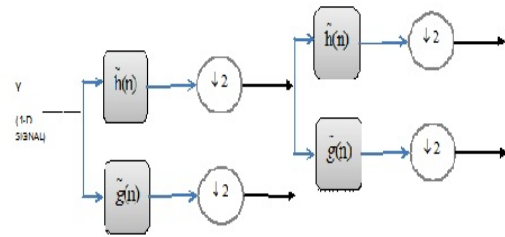

Fig. 1 Analysis of Discrete Wavelet Transform

A wavelet basis is a collection of translation and dilation of the basic mother wavelet ψ , together with translation of the scaling function ϕ . For the transmission signal of length N (which should be power of 2), the wavelet dictionary collection can be described as follows:

$$M = \log_2(N)$$

$$f_1(j, k) = \psi(2^j t) = 2^{-\frac{j+1}{2}} \sum_{k=0}^{N-1} g(n) \phi(2^{j+1} t - k) \quad j = 1 \text{ to } M-1$$

$$f_2(k) = \phi(t) = \sqrt{2} \sum_{k=0}^{N-1} h(n) \phi(2t - k)$$

The wavelet transform basically involves filtering of the signal with low pass filter $h(n)$ and a high pass filter $g(n)$. as shown in Fig 1. Each of the wavelet dictionary are created using these two filters. In linear algebra point of view, the wavelet transform can be thought of matrix vector multiplication.

$$y = Wx$$

W is a mathematical representation of the filter bank structure and it is called wavelet matrix. During wavelet decomposition, in each level, the signal size is decreased to half of its original size. Wavelet matrix actually helps to align and makes all the dictionaries occupy the same interval. Specifically, the transmitting signal of length N undergoes $M = \log_2(N)$ levels of decomposition. The wavelet matrix for this case can be written as,

$$W_k^{(N)} = \begin{bmatrix} W_1^{\frac{N}{2^{k-1}}} & 0 \\ 0 & I_{\frac{N-N}{2^{k-1}}} \end{bmatrix} \begin{bmatrix} W_1^{\frac{N}{2^{k-2}}} & 0 \\ 0 & I_{\frac{N-N}{2^{k-2}}} \end{bmatrix} \dots \begin{bmatrix} W_1^{\frac{N}{2}} & 0 \\ 0 & I_{\frac{N}{2}} \end{bmatrix} W_1^{(N)} \quad (2)$$

where $W_1^{(N)}$ represent 1 scale wavelet transform matrix. Once $W_1^{(N)}$ is computed, the subsequent matrix $W_2^{\frac{N}{2}}, W_3^{\frac{N}{4}}, \dots, W_{M-1}^{\frac{N}{2^{M-1}}}$ can be generated easily and therefore k scale wavelet matrix can be obtained as described in eq 2. Thus the wavelet matrix ($W_{N \times N}$) of dimension $N \times N$ is obtained.

The wavelet matrix contains the orthonormal wavelet basis column wise. So this matrix can be used for modulation and demodulation in OFDM. In the transmitter side, modulation can be done by loading the message to each of the wavelet subcarriers in parallel. This process is called IDWT(Inverse Discrete Wavelet Transform), which can be accomplished by multiplying the input message x with the wavelet matrix W .

$$Y_{N \times 1} = W_{N \times N} x_{N \times 1}$$

In receiver side, the demodulation takes place by multiplying Y with W' (Inverse of W). This operation is equivalent to DWT.

$$\tilde{x}_{N \times 1} = W'_{N \times N} Y_{N \times 1}$$

Since W is an orthonormal basis set, IFFT in traditional OFDM system can be replaced with IDWT and FFT by DWT. The DWT based OFDM has an advantage that it can suppress side lobes to a great extent. Also loss of orthogonality in wavelet subcarriers leads to less ISI and ICI.

C. Dual Tree Complex Wavelet Transform(DTCWT)

One of the major drawback with DWT based systems is that the system is sensitive to shift in the input signal. A slight change in the input signal incorporates unpredictable change in the DWT coefficients. Since there is a chance that the signal doesn't remain stationary in the sub band, the energy across the sub band also changes. Also, DWT doesn't provide phase information which can describe the non stationary behaviour of the transmitting signal. In order to overcome these difficulties, Complex Wavelet Transform(CWT) has been proposed. CWT is shift in variance and it gives explicit phase information.

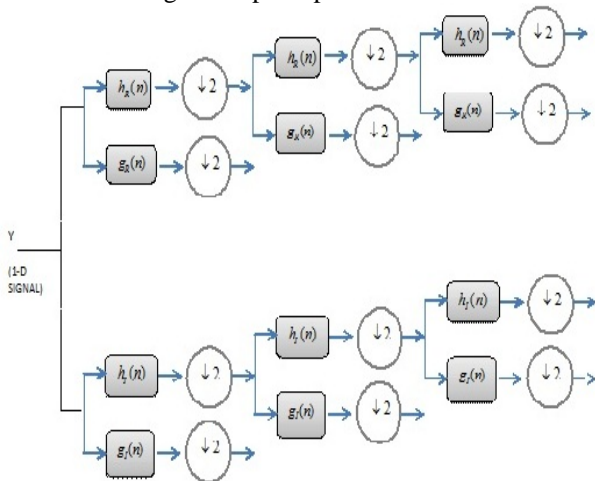

Fig. 2 Analysis of Dual Tree Complex Wavelet Transform

Kingsbury introduces DTCWT. It is redundant complex wavelet transform design. It involves two DWT's. The upper part involves real part of the transform(denoted as tree R) while the lower part contains imaginary part(tree I).

DTCWT contains 2 low pass filters $h_R(t), h_I(t)$, one for tree R and another for tree I respectively. Similarly, the

design also contains 2 high pass filters $g_R(t), g_I(t)$. The wavelet dictionary for DTCWT can be defined as follows:

$$M = \log_2(N)$$

$$f_{1R}(j, k) = \psi_R(2^j t) = 2^{-\frac{j+1}{2}} \sum_{k=0}^{N-1} g_R(n) \phi_R(2^{j+1} t - k) \quad j = 1 \text{ to } M-1$$

$$f_{2R}(k) = \phi_R(t) = \sqrt{2} \sum_{k=0}^{N-1} h_R(n) \phi_R(2t - k)$$

$$f_{1I}(j, k) = \psi_I(2^j t) = 2^{-\frac{j+1}{2}} \sum_{k=0}^{N-1} g_I(n) \phi_I(2^{j+1} t - k) \quad j = 1 \text{ to } M-1$$

$$f_{2I}(k) = \phi_I(t) = \sqrt{2} \sum_{k=0}^{N-1} h_I(n) \phi_I(2t - k)$$

The design of DTCWT is redundant because it contains a pair of filter bank that operates simultaneously on the input data. The design of the transform is such that the wavelet associated with the filter banks are a Hilbert pair, that is, $\psi_I(t) = H[\psi_R(t)]$. The design of the filter in such a manner makes it feasible to obtain real and imaginary part of the transform for the same input signal.

The heart of DTCWT depends on design of the two wavelet function as mentioned above. Since wavelet design depends on the filter design, the problem gets reduced to a filter design problem. It can be proved that, if the low pass filters are designed in such a way that one of them is half sample shift of the other, DTCWT can be designed.

$$h_I(n) = h_R(n - 0.5) \Rightarrow \psi_I(t) = H[\psi_R(t)]$$

If W_R correspond to the wavelet matrix for DWT tree R and W_I correspond to that of DWT tree I, then the wavelet matrix of DTCWT W can be written as,

$$W = \frac{1}{\sqrt{2}} \begin{bmatrix} I & jI \\ I & -jI \end{bmatrix} \begin{bmatrix} W_R \\ W_I \end{bmatrix}$$

It can be seen that if N orthonormal DWT subcarriers are generated by Tree R and Tree I, it is possible to generate $2N$ subcarriers for DTCWT.

$$(W)_{2N \times N} = \frac{1}{\sqrt{2}} \begin{bmatrix} I & jI \\ I & -jI \end{bmatrix}_{2N \times 2N} \begin{bmatrix} (W_R)_{N \times N} \\ (W_I)_{N \times N} \end{bmatrix}_{2N \times N}$$

The inverse of W can be calculated as

$$W'_{N \times 2N} = W^{-1} = \frac{1}{\sqrt{2}} \begin{bmatrix} W_R^{-1} & W_I^{-1} \\ -jI & jI \end{bmatrix} \begin{bmatrix} I & I \\ -jI & jI \end{bmatrix}$$

Even though W and W^{-1} are non square matrix, they are orthogonal.

$$W_{2N \times N} W'_{N \times 2N} = I_{2N \times 2N}$$

There is an interesting phenomenon that is observed in modulation and demodulation step using DTCWT. If IDTCWT is used in transmitter, the incoming signal x of

size M need to be multiplied with the matrix W' to get modulated signal Y .

$$Y_{\frac{M}{2} \times 1} = (W)_{\frac{M}{2} \times M} (x)_{M \times 1}$$

It can be seen that each of the subcarriers has the length of $\frac{M}{2}$ only. So the length of the data to be transmitted has been reduced. This significantly reduce the hardware complexity of the OFDM system.

In the receiver side, the data is estimated by projecting Y to the DTCWT basis with the aid of wavelet matrix.

$$x_{M \times 1} = (W)_{M \times \frac{M}{2}} (Y)_{\frac{M}{2} \times 1}$$

IV. OFDM SYSTEM BASED ON DT-CWT

Any communication system can be broadly classified as three blocks: transmitter, Channel and Receiver. The user information, which is of digital form, is generated, modulated and transmitted. The transmitted message gets affected due to channel parameters and noise. The receiver receives signal, demodulate and interprets the transmitted signal. This is the simplest explanation of any communication system.

Orthogonal Frequency-Division Multiplexing (OFDM) is a method of encoding digital data on multiple carrier frequencies. This section aims at understanding the mathematics behind each step in OFDM based on DTCWT. Fig 3 represents the block diagram of traditional OFDM system and Fig 4 correspond to that of DTCWT based OFDM system.

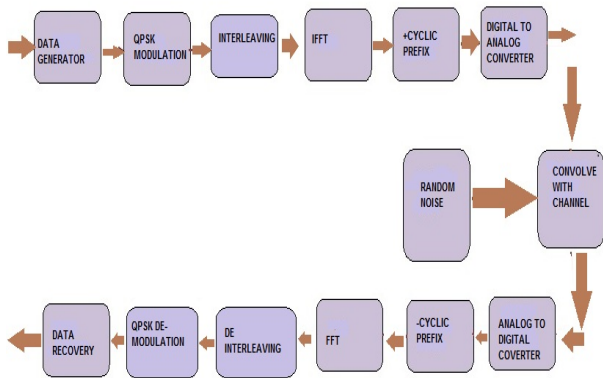

Fig. 3 OFDM based on FFT

In traditional OFDM system, Cyclic Prefix(CP) are added so as to avoid ISI. But in DTCWT, due to overlapping nature of wavelets, there is no need of adding CP to deal with the delay spread of the channel. This reduces the length of the data to be transmitted in transmitter. Also, in demodulation based of IDTCWT, the length of the subcarriers is only half of that of number of subcarriers. Because of these two factors, the length of the signal that is transmitted is very less than that of conventional OFDM system. This greatly reduces the bandwidth of the system. This leads to optimization of transmission power. Added to

it, DTCWT based OFDM implementation in hardware is easy when compared to current OFDM system.

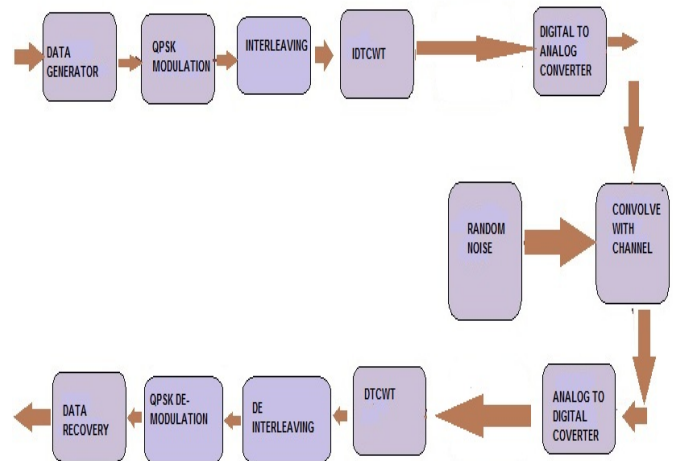

Fig. 4 OFDM based on DT-CWT

This section aims to explain the mathematics behind various steps involved in DTCWT based OFDM system. Each of the block is analysed with the aid of a simple example. The data that need to be transmitted is **00111101**.

1. The first step is to convert the user data into Quadratic Phase Shift Keying(QPSK) scheme. In QPSK, two bits are taken and are assigned a complex symbol based on the value of the two bits as shown below:

After mapping the input data to complex symbols, the 8×1 user data is converted into 4×1 data.

$$\begin{pmatrix} 1+i \\ 1-i \\ 1-i \\ -1+i \end{pmatrix}_{4 \times 1}$$

2. The next step is interleaving of data (ie) the same 4 bit symbol is repeated 4 times to make the system more resistant to error. So the 4×1 data has been converted into 16×1 data as shown below:

$$\begin{pmatrix} 1+i \\ 1-i \\ 1-i \\ -1+i \end{pmatrix}_{4 \times 1} \Rightarrow \begin{pmatrix} 1+i \\ 1-i \\ 1-i \\ -1+i \\ 1+i \\ 1-i \\ 1-i \\ -1+i \\ 1+i \\ 1-i \\ 1-i \\ -1+i \\ 1+i \\ 1-i \\ 1-i \\ -1+i \end{pmatrix}_{16 \times 1}$$

The 1st bit, 5th bit, 9th bit and 13th bit contains the same information. The reason for doing this interleaving is that even if the first bit is affected by noise, it can be recovered using rest of the 3 bits(5th, 8th and 13th bit).

There are various ways of interleaving data. But this way of interleaving increases the robustness of the system. Interleaving can also be done by repeating 1st bit 4 times, then 2nd bit 4 times etc. But this may lead to burst error. So this type of interleaving is not done.

- The next is the most crucial step. The 16x1 data is loaded into DTCWT (subcarriers) as shown below:

$$\begin{pmatrix} x(0) \\ x(1) \\ \vdots \\ x(7) \end{pmatrix}_{8 \times 1} = \begin{pmatrix} | & | & & | \\ | & | & & | \\ | & | & & | \\ | & | & & | \\ | & | & & | \\ | & | & & | \\ | & | & & | \\ | & | & & | \end{pmatrix} \begin{pmatrix} 1+i \\ 1-i \\ \vdots \\ -1+i \end{pmatrix}_{16 \times 1}$$

Base1 Base2 ... Base16

So the vector X left side is written as linear combination of each complex symbol with its complex base. Each complex symbol changes the phase of DFCWT subcarrier and the change of phase is taken as information in OFDM.

The above process is IDTCWT. So in order to carry out this step, IDTCWT of the input sequence is performed in transmitter. In the receiver side, DTCWT is taken to retrieve the original message.

It can be seen that after modulation, the input signal of size 16x1 has been reduced to 8x1.

- The next step in traditional OFDM is the addition of cyclic prefix. This step is performed in order to reduce Inter Symbol Interference(ISI). But due to overlapping nature of wavelet, this step is avoided in Dual Tree OFDM, which increases the spectral efficiency of the system.

The transmitted signal is sent. The signal passes through the channel. In channel, the signal gets convolves with the channel coefficient. In this example three channel coefficient are present.

- In channel, Random noise gets added to the transmitted signal. Some of the common noise that occurs in channel are Additive White Gaussian Noise(AWGN), Uniform Noise, Impulse Noise etc. In this paper, white gaussian noise is added manually to the signal.
- The Noise affected channel is received at the receiver. The algorithm at receiver just inverses the process done in transmitter. Last two bits which are being added due to convolution with the channel are removed and only the message of 8x1 is considered.
- The next step is to retrieve the message from the complex wavelet subcarriers. For doing so, DTCWT is used.

$$\begin{pmatrix} x(0) \\ x(1) \\ \vdots \\ x(15) \end{pmatrix}_{16 \times 1} = \begin{pmatrix} | & | & & | \\ | & | & & | \\ | & | & & | \\ | & | & & | \\ | & | & & | \\ | & | & & | \\ | & | & & | \\ | & | & & | \end{pmatrix} \begin{pmatrix} X(0) \\ X(1) \\ \vdots \\ X(7) \end{pmatrix}_{8 \times 1}$$

Base1 Base2 ... Base8
Base9 Base10 ... Base16

$$\begin{pmatrix} x(0) \\ x(1) \\ \vdots \\ x(15) \end{pmatrix}_{16 \times 1} = \begin{pmatrix} - & - & \overline{Base1} & - & - \\ - & - & \overline{Base2} & - & - \\ & & \vdots & & \\ - & - & \vdots & - & - \\ - & - & \vdots & - & - \\ & & \vdots & & \\ - & - & \overline{Base15} & - & - \\ - & - & \overline{Base16} & - & - \end{pmatrix}_{16 \times 8} \begin{pmatrix} X(0) \\ X(1) \\ \vdots \\ X(7) \end{pmatrix}_{8 \times 1}$$

where \hat{x} sequence represent the received signal and \hat{X} sequence represent the demodulated signal.

- The next step is to perform de convolution on the data . If H represents the FFT of channel coefficients, then multiplying the signal with conjugate of H performs de convolution of the data.
- The step involves De-interleaving (i.e.) from 16x1, the transmitted signal 4x1 has to be estimated. It is done as shown below:

$$\begin{pmatrix} \hat{x}(0) \\ \hat{x}(1) \\ \hat{x}(2) \\ \hat{x}(3) \\ \hat{x}(4) \\ \hat{x}(5) \\ \hat{x}(6) \\ \hat{x}(7) \\ \hat{x}(8) \\ \hat{x}(9) \\ \hat{x}(10) \\ \hat{x}(11) \\ \hat{x}(12) \\ \hat{x}(13) \\ \hat{x}(14) \\ \hat{x}(15) \end{pmatrix}_{16 \times 1} \Rightarrow \begin{pmatrix} \frac{\hat{x}(0) + \hat{x}(4) + \hat{x}(8) + \hat{x}(12)}{4} \\ \frac{\hat{x}(1) + \hat{x}(5) + \hat{x}(9) + \hat{x}(13)}{4} \\ \frac{\hat{x}(2) + \hat{x}(6) + \hat{x}(10) + \hat{x}(14)}{4} \\ \frac{\hat{x}(3) + \hat{x}(7) + \hat{x}(11) + \hat{x}(15)}{4} \end{pmatrix}_{4 \times 1}$$

- The final step involves estimating the transmitted signal from the received signal. This is done by applying the De-interleaved data in complex plane and estimating the transmitted bits.
- Now the estimated signal is compared with the actual transmitted signal and the performance of the system is analysed.

V. PERFORMANCE EVALUATION

Bit Error Rate(BER) and Peak Average Power Ratio(PAPR) are the two important parameter which is used to measure the performance of the OFDM system. This section is dedicated in explaining these parameters.

A. Bit Error Rate(BER)

Bit Error rate is the parameter which is used to fit a number to represent the number of received bit that has been altered due to noise, interference or distortion, etc. It is one of the most important assessment to an communication system. BER measures the full end to end performance of the system including the transmitter, receiver and the medium between the two.

BER is defined as the rate in which error occur in the OFDM system. Mathematically, the parameter is defined as

$$BER = \frac{\# Errors}{\# Bits send}$$

where # represent total count. In digital communication information is transmitted as 0's and 1's. Error occurs if the bits get flipped during transmission.

In this work, BER is evaluated for various σ , where σ represent the variance of noise. A plot has been made between BER versus $\left(\frac{1}{\sigma^2}\right)$.

B. Peak Average Power Ratio(PAPR)

The PAPR of the OFDM system is defined as the ratio between the instantaneous power and its average power. It is given by the formula,

$$PAPR = \frac{\max [x(n).x(n)^*]}{E [x(n).x(n)^*]}$$

where $x(n)$ is the transmitted signal and $x(n)^*$ is the complex conjugate of $x(n)$.

In OFDM, the modulated signal $x(n)$ doing into the channel is the linear sum of random symbols modulating orthogonal basis function. In case of FFT, the random symbol used are Fourier basis. On the other hand, in DTCWT, complex wavelet basis are used to represent $x(n)$. By Central Limit Theorem(CLT), it can be proved that $x(n)$ is complex Guassian and its envelope follows Rayleigh distribution. This leads to high PAPR.

In order to make OFDM system effective, low PAPR is desired. Thus PAPR is a good parameter for comparing OFDM systems with various modulation schemes.

In the literature, the Complementary Cumulative Distribution Function(CCDF) of the Peak Average to Power Ratio(PAPR) is often used as a criteria. Given a reference level $PAPR_0$, the probability of PAPR greater than the reference value is given by CCDF and it is given by the formula

$$CCDF(PAPR_0) = p(PAPR > PAPR_0)$$

VI. OFDM MODEL SIMULATION

The OFDM communication system is simulated using Matlab.Two parameters, PAPR and BER are considered for performance evaluation of various modulations in OFDM.

The simulated OFDM is scrutinized under different SNR. Ten value of Signal to Noise Ratio(SNR(in db)) is selected in the range 0 to 20. The corresponding variance of noise is

formulated as $\sigma = \frac{1}{10^{SNR/10}}$. The value of N(length of the

data) and Nch(Number of channel coefficients) are obtained from the user. For the given N, Nch, σ values, a single OFDM simulation involves generation of random data in digital format, modulation using IFFT/IDWT/IDTCWT, addition of random white gaussian noise and demodulation by the counterpart that is used in modulation. For each of the ten σ values, OFDM communication is simulated for 10000 times.

The average BER is computed for each σ .From the obtained value, a plot is obtained which describes the behaviour of BER versus $\frac{1}{\sigma^2}$. Also, PAPR is computed for a particular σ and then CCDF is calculated. The separate plot is done for CCDF versus $PAPR_0$.

A. Simulation Testing

The OFDM model is tested for 3 different cases. For each of the case, the performance of the system is evaluated using PAPR and BER plots. The three different cases are listed below:

- 1) Three OFDM system model is simulated using different modulations FFT and DTCWT and its performance is compared and analysed.
- 2) Different DTCWT based OFDM systems are simulated. DTCWT uses different filters in the initial first stage of the filter bank and a new set of filters in rest of the stages. Some of the filters used in the first stage are Legall 5,3 tap filters, Antonini 9,7 tap filters, Near Symmetric 5,7 tap filters(n-sym-a),Near Symmetric 13,19 tap filters(n-sym-b). Also, Quarter Sample Shift Orthogonal 10,10 tap filters(Q-sh-a) with 10,10 non zero taps, Quarter Sample Shift Orthogonal 14,14 tap filters(Q-sh-b), Quarter Sample Shift Orthogonal 16,16 tap filters(Q-sh-c), Quarter Sample Shift Orthogonal 18,18 tap filters(Q-sh-d) are the candidates for the successive stages of the filter bank. The filter coefficients values for each of the filters are provided in appendix.

Ten different DTCWT system are generated by taking various combination of filters in first and successive filter bank stages,which is listed in Table I.The performance is evaluated for each of the system.

TABLE II
DESIGN OF DT-CWT SYSTEM

S.no	DT-CWT system specification		
	DT-CWT system	First stage filter	Successive stage filter
1	DT-CWT-1	Legall 5,3	Q-sh-06
2	DT-CWT-2	Legall 5,3	Q-sh-a
3	DT-CWT-3	Antonini 9,7	Q-sh-d
4	DT-CWT-4	n-sym-a	Q-sh-a
5	DT-CWT-5	n-sym-b	Q-sh-b
6	DT-CWT-6	n-sym-a	Q-sh-c
7	DT-CWT-7	Antonini 9,7	Q-sh-a
8	DT-CWT-8	n-sym-a	Q-sh-c
9	DT-CWT-9	n-sym-b	Q-sh-d
10	DT-CWT-10	n-sym-b	Q-sh-06

3) The communication model is simulated for various length of subcarriers N:64,128,256,512,1024.

4)

B. Results

The OFDM models were simulated for all the above three cases mentioned. The comparative study has been made with the help of PAPR and BER plots.

1) PAPR Analysis

The models built for the first case helps to analyse PAPR for OFDM modulated using FFT,DTCWT. The CCDF plot for the same is given in Fig 5. From the plot, it is clear that DTCWT has very less PAPR when compared to rest of the two methods. It has 5 db less PAPR when compared to other two systems.

In the next case, the PAPR analysis helps to figure out the best candidate for DTCWT system; Fig 6 provides CCDF plot for various DTCWT systems. It can be seen that almost all the system has same performance and there is no significant degradation by the use of different set of filters. In order to understand the effect of subcarriers on PAPR performance, OFDM models are simulated for traditional OFDM system and DTCWT-OFDM system for various subcarriers. The results are plotted in Fig 7 and Fig 8. It can be observed that DTCWT outperforms traditional OFDM system for different subcarriers count. Also, it is obvious from the plot that increase in subcarriers results doesn't increase the PAPR significantly in DTCWT-OFDM system.

2) BER Analysis

For the three different scenarios, the performance of the system is evaluated with the aid of BER plot, which are shown in fig 9-12. For the first case, it can be observed that DTCWT based system has almost same BER when compared to traditional OFDM system. But BER significantly improved for the system for large value of N(Number of subcarriers)

3) Tabulation Results

The table below (Table IIIIV and Table VVIVII)summarizes the overall numerical results obtained with the aid of the simulation experiment.

TABLE VIIIIX
PERFORMANCE ANALYSIS OF VARIOUS DT-CWT SYSTEM

S.no	Performance Analysis		
	OFDM system	BER	PAPR(in dB)
1	OFDM-FFT	0.48	9
2	OFDM-DT-CWT_1	0.42	3
3	OFDM-DT-CWT_5	0.51	2.8
4	OFDM-DT-CWT_10	0.46	2.9

TABLE XXIXII
EFFECT OF LENGTH OF SUBCARRIERS ON OFDM SYSTEM

Performance Analysis			
OFDM system	N	BER	PAPR(in dB)
OFDM-FFT	32	0.49	6
	64	0.49	7
	128	0.5	9
	256	0.48	13
	512	0.5	16
OFDM-DT-CWT	32	0.49	2
	64	0.51	2
	128	0.48	5
	256	0.5	5
	512	0.51	7

4) Discussion

A comparative study has been made between OFDM systems built using two modulation schemes: Fourier and complex wavelet.The system is analysed for various criteria; PAPR and BER are used as performance measure in each of the case . Numerical measurement shows that DTCWT has better performance than FFT based system. Also the new system has added advantage that it can be easily designed compared to the formal system.

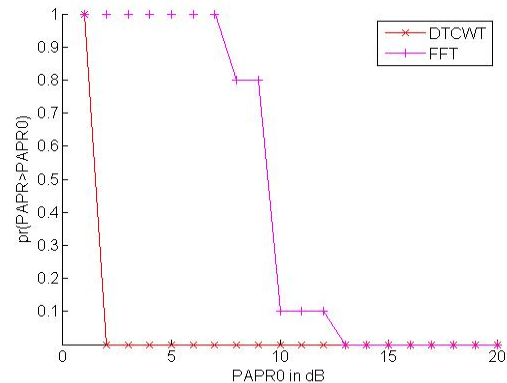

Fig.5 CCDF of OFDM-FFT vs OFDM-DTCWT

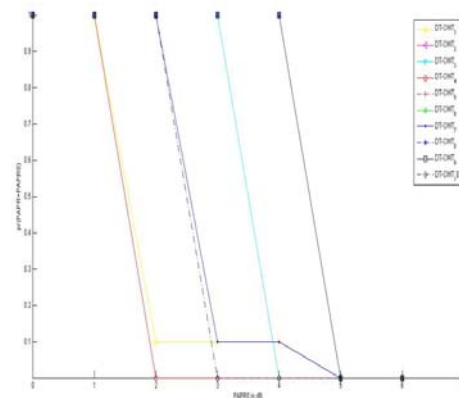

Fig. 6 CCDF of various DTCWT system

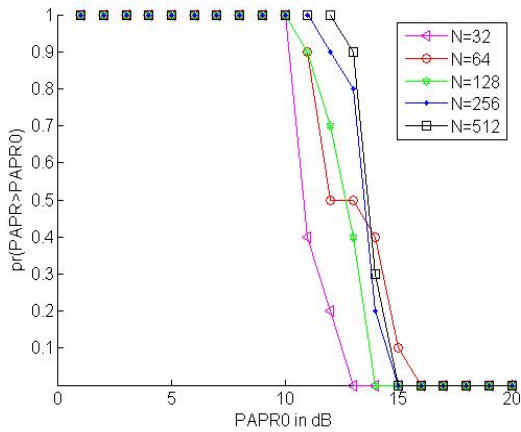

Fig. 7 CCDF of OFDM-FFT for various N

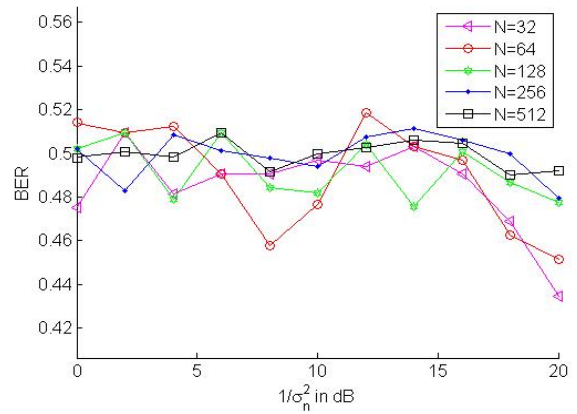

Fig. 11 BER of OFDM-FFT for various N

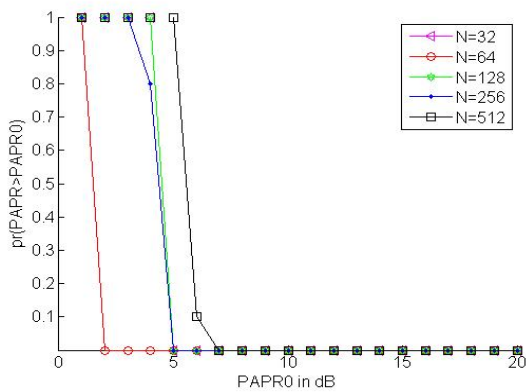

Fig. 8 CCDF of OFDM-DTCWT for various N

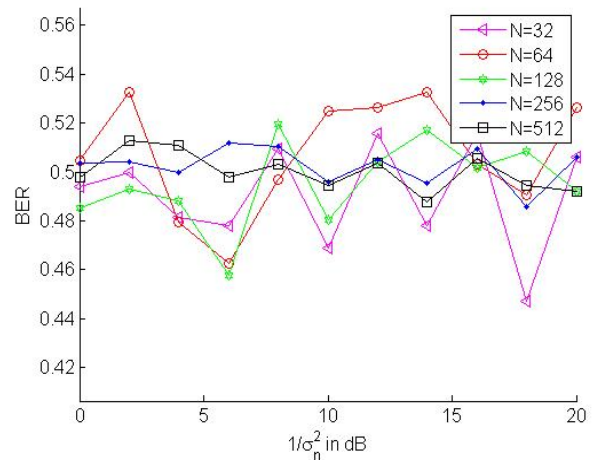

Fig. 12 BER of OFDM-DTCWT for various N
ACKNOWLEDGMENT

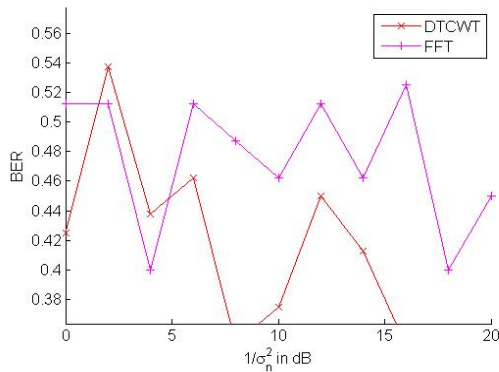

Fig. 9 BER of OFDM-FFT vs OFDM-DTCWT

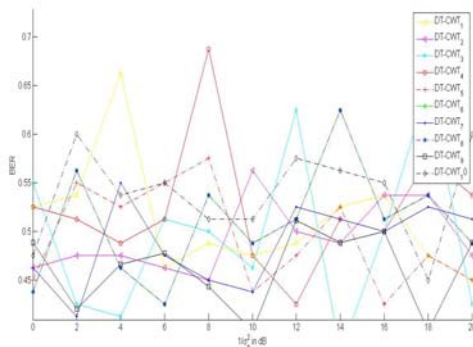

Fig. 10 BER of various DTCWT system

VII. CONCLUSIONS

Traditional OFDM system suffers from several drawbacks. One of its primary drawback is high PAPR. In order to overcome the difficulties, a new OFDM system has been proposed based on DTCWT. An effort has been made to understand the mathematics behind OFDM system built with the aid of DTCWT. The OFDM model is also simulated using Matlab. Several experimental simulation suggested that the proposed system has low PAPR and BER when compared to the existing system. Also, by using the newly proposed system, the length of the transmitting data gets reduced by half which reduces bandwidth and transmission power. This also facilitate easy implementation of the system using FPGA. Owing to all these merits, it can be concluded that DTCWT has potential advantage to replace traditional OFDM system.

ACKNOWLEDGEMENT

The authors would like to acknowledge Sowmya V , and Soman K P of CEN Dept, Amrita Vishwa Vidyapeetham, Coimbatore, for their immense support for completing this paper. Also the authors would like to thank the Almighty and their parents whose blessings are always with them.

REFERENCES

- [1] Mohamed H. M. Nerma, Varun Jeoti Jagadish, and Nidal Nidal S. Kamel, "The Effects of Shift-invariance Property in DTCWT OFDM System," In Proc IEEE 2012 International Conference on Innovations in Information Technology (IIT) pp:17-21, March 2012.
- [2] Mohamed H. M. Nerma, Varun Jeoti Jagadish, and Nidal Nidal S. Kamel, "On DT-CWT Based OFDM: PAPR Analysis," In Proc Multicarrier systems and solutions Volume 41 pp:207-217 2009.
- [3] Mohamed H. M. Nerma, Varun Jeoti Jagadish, and Nidal Nidal S. Kamel, "Investigation of Using Dual Tree Complex Wavelet Transform (DT-CWT) to Improve the Performance of OFDM System," In Proc IAENG Volume 20:2 Advance online publication: 26 May 2012.
- [4] Mohamed H. M. Nerma, Varun Jeoti Jagadish, and Nidal Nidal S. Kamel, "Performance Analysis of a Novel OFDM System Based on Dual – Tree Complex Wavelet Transform (DT-CWT)," Proc. UbiCC Journal, Volume 4:3, August 2009
- [5] Anand R, Prabha P, Sikha OK, Suchitra M, Sukanya P, Sowmya V, Soman KP, "Visualization Of OFDM Using Microsoft Excel Spreadsheet In Linear Algebra Perspective ", International Conference on Advances in Computing and Communication (ICACC), pg-58-64, Aug 2012.
- [6] Mohamed H. M. Nerma, Varun Jeoti Jagadish, and Nidal Nidal S. Kamel, "An OFDM System Based on Dual Tree Complex Wavelet Transform (DT-CWT)," Signal Processing: An International Journal (SPIJ), Volume (3) : Issue (2) May 2009.
- [7] Steffen Bittner, Marco Krondorf, and Gerhard Fettweis, "Numerical Performance Evaluation of OFDM Systems affected by Transmitter Nonlinearities, Phase Noise and Channel Estimation Errors," in Proc. Global Telecommunications conference pp.1-6, 2008.
- [8] Mrs. VEENA M.B, and Dr. M.N.SHANMUKHA SWAMY, "Performance analysis of DWT based OFDM over FFT based OFDM and implementing on FPGA," In Proc International Journal of VLSI design and Communication Systems (VLSICS) Vol.2, No.3, September 2011.
- [9] Suverna Sengar, and Partha Pratim Bhattacharya, "PERFORMANCE IMPROVEMENT IN OFDM SYSTEM BY PAPR REDUCTION," In Proc MSIGNAL and Image Processing : An International Journal (SIPIJ) Vol.3, No.2, April 2012.
- [10] Mickael LALLART, Keith E. NOLAN, Paul SUTTON, and Linda E. DOYLE, "On-The-Fly Synchronization Using Wavelet and Wavelet Packet OFDM," In Proc PIMRC 2008.
- [11] Aladdin Amro, "A Flexible OFDM System Simulation Model with BER Performance Test," In Proc Contemporary Engineering Sciences, Vol. 5, 2012, no. 8, pp:365 - 374 June 2012.
- [12] Ivan W. Selesnick, Richard G. Baraniuk, and Nick G, "Dual tree Complex Wavelet Transform," In Proc IEEE SIGNAL PROCESSING MAGAZINE pp. 123–151, Nov. 2005.
- [13] Felix C.A. Fernandes, Ivan W. Selesnick, Rutger L.C. van Spaendonck, and C. Sidney Burrus "Complex wavelet transforms with allpass filters," In Proc Elsevier Signal Processing 83 (2003) 1689 – 1706.
- [14] Rohit Bodhe, Shirish Joshi, and Satish Narkhede, "Performance Comparison of FFT and DWT based OFDM and Selection of Mother Wavelet for OFDM," (IJCSIT) International Journal of Computer Science and Information Technologies, Vol. 3 (3) , 2012, 3993-3997.
- [15] Zhao Li, Jiawei Yang, and Junliang Yao, "Adaptive Opportunistic Transmission in MU-MIMO Downlink with Reduced Feedback," Journal of Communications ISSN 1796-2021 Volume 5, Number 7, July 2010.
- [16] Hikmat N. Abdullah, and Fadhil S. Hasan, "Performance Evaluation of Complex Wavelet Packet Modulation (CWPM) System over Multipath Rayleigh Fading Channel," Journal of Signal and Information Processing, 2012, 3, 352-359.
- [17] Evgeny Vanin, "Performance evaluation of intensity modulated optical OFDM system with digital baseband distortion," In Proc Optical Society of America 28 February 2011 / Vol. 19, No. 5
- [18] R. Asif, R. A. Abd-Alhameed, O.O. Anoh and Y.A.S. Dama, "Performance Evaluation of DWT-FDM and FFT-OFDM for Multicarrier Communications Systems using Time Domain Zero Forcing Equalization," In Proc International Journal of Computer Applications (0975 – 8887) Volume 51– No.4, August 2012.
- [19] Adeel Abbas and Trac D, "Rational Coefficient Dual-Tree Complex Wavelet Transform: Design and Implementation," In Proc IEEE TRANSACTIONS ON SIGNAL PROCESSING, VOL. 56, NO. 8, AUGUST 2008.
- [20] Adeel Abbas and Trac D, "Rational Coefficient Dual-Tree Complex Wavelet Transform: Design and Implementation," In Proc IEEE TRANSACTIONS ON SIGNAL PROCESSING, VOL. 56, NO. 8, AUGUST 2008.
- [21] Swati Sharma and Sanjeev Kumar, "BER Performance Evaluation of FFT-OFDM and DWT-OFDM," In Proc International Journal of Network and Mobile Technologies ISSN 2229-9114 Electronic Version VOL 2 / ISSUE 2 / MAY 2011.
- [22] Gurpreet Kaur and Partha Pratim Bhattacharya, "Performance Evaluation of an OFDM System under Rayleigh Fading Environment," In Proc Journal of Emerging Trends in Computing and Information Sciences ISSN 2079-8407 VOL. 3, NO. 3, March 2012.